Part XVII Connecting the Dots - Part 6 Enlightenment

Author : Meiliken

Date : 24-12-2019

Phi and the Four(4) Essential Elements

We just finished another section where we showed that the mathematical constant Phi(?) was at the epicenter of the physical movement of even the unseen forces and fields in our universe, those that led to electricity and magnetism, etc. We are going to circle back to the Torah again. The first verse of the *Shema*, also known as the **15** Triplets of the **4** essential Elements has a numerical value of **1118**. Quite simply it is equivalent to (Phi² or **2.6180...**) less **1.5000**, which equals **1.1180...** For anyone that has not been following this series from its inception, you can find the [entire work here](#).

$$\varphi^2 - 1.5 = 1.1180 \dots$$

$$\varphi - .5 = 1.1180 \dots$$

There are **1000** letters in the *Shema*, and (Phi² - Phi) = **1.000...**

$$\varphi^2 - \varphi = 1.000 \dots$$

Of the **2¹⁰** word values in the Torah, the highest is **1500**. Another Name of G-d is *YaH*(??) of numerical value **15**; it is in the aspect of the upper three *sefirot* (dimensions), in other words, it is above and beyond the Plane of Inertia. It is the aspect of the place from which the waters surge, the place of Light (Life) force. The Name *Yah* (??) is the Name associated with *Chochma*, above and beyond *Binah*. Moreover, when the letters in the Tetragrammaton (????) are multiplied together they equal **1500**. We could then say that the *Shema* plus with *YaH* (??) or (????) equals Phi(?).

$$\varphi^2 - \varphi = Shema$$

$$Shema + יה = \varphi^2$$

$$Shema + יהוה = \varphi^2$$

Therefore: $Shema + יהוה - \varphi = Shema = 1$

“He and His Name are One.”

At the time of the Flood, the Torah makes a point of telling us “all the wellsprings of the great deep burst forth and the floodgates of the heavens were opened” and “the waters surged upwards **15** cubits and covered the mountains.” Two equal and opposite directions; two equal and opposite forces flooding our world. The waters surged over the earth for **150** days and receded on the earth for **150** days. Two equal and opposite actions, or two equal and opposite forces interacting with our physical world, convergence and divergence.

Peter pointed out to us that the **7** Bell Prime Indices that we discussed earlier in this series in relation to the *Shema* etc. sum up to **2963**, which is exactly **6180** or (**Phi x 10**) less than the **9143**-total value of the **72** Triplets. We have seen Phi entrenched in the Torah, quantitatively and computationally, and have seen it in the **14** Triplets of the **42**-Letter Name of G-d; and in the **11** Triplets of the Torah’s first **8** Words; and have just seen it in the *Shema*; and now we see it in the **72** Triplets as well. If you recall, the **7** Bell Prime Indices were connected to the *Shema* through their sequential **13 – 42 – 55** *Alefs*(?), and the *Alefs*(?) itself is also connected to *Phi*(?), through its **4** extremities as discussed in the previous section.

The *Shema* and the Torah connect to *Phi*(?) in yet another way. There are **248** words in the *Shema* and **1000** letters in the *Shema*, and (**248 x 1000**) = **248,000**, which matches up beautifully with the **401,273** total words, letters, verses, rows and columns in the Torah divided by *Phi*(?):

$$\frac{401,273}{\varphi} = 248,000$$

Generating Vortices

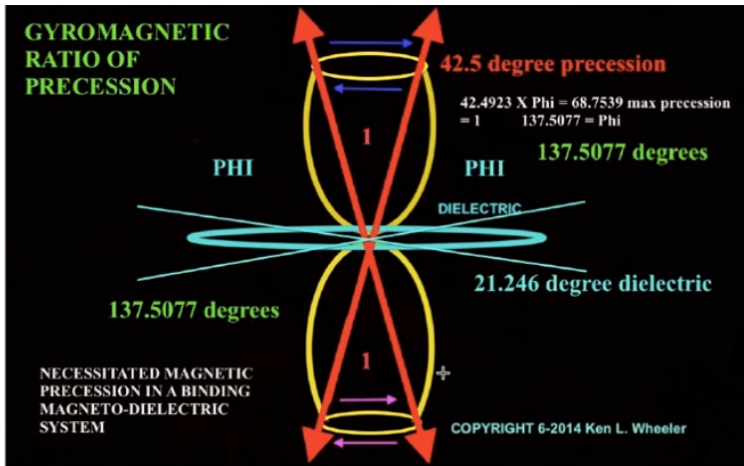

As we said earlier, the 6-cubit thick walls of the Holy Temple are 13.75 ft wide, analogous to the naturally efficient 137.50° Phi angle. The 137.50° angle is the angle from the precession to the dielectric plane of inertia, which within the $A/ef(?)$ is analogous to the $Vavs(??)$ or numeric value 6.

The following set of diagrams have nothing to do with Ken Wheeler's work or Steinmetz's, yet indirectly everything. They are Phi(?) progressions, including Ken's all-important Φ^3 , of circles and angles, and they not only lead to the design of vortices, but to the $A/ef(?)$ once again. The ratio of any two numbers that are added together to get the next number in a sequence will tend to Phi(?) over the long term, which can be easily proven with eigenvectors or simple computation.

$$F_n = F_{n-1} + F_{n-2}$$

$$\begin{pmatrix} F_n \\ F_{n-1} \end{pmatrix} = \begin{pmatrix} 1 & 1 \\ 1 & 0 \end{pmatrix} \begin{pmatrix} F_{n-1} \\ F_{n-2} \end{pmatrix} \quad \frac{233}{144} = 1.618, \quad \frac{1037}{641} = 1.618, \quad \frac{1570}{970} = 1.619$$

0, 1, 1, 2, 3, 5, 8, 13, 21, 34, 55, 89, 144, 233....

3, 17, 20, 37, 57, 94, 151, 245, 396, 641, 1037....

10, 40, 50, 90, 140, 230, 370, 600, 970, 1570,

This means that a Phi(?) vector can be drawn through any two numbers, and that every number has an infinite number of Phi(?) vectors that can be drawn through it. The number 1 can be

paired with 2 to start off the Fibonacci (Phi-based) sequence (1,2,3,5,8,13...); or it can be paired with 3 and quickly become a Phi(?) sequence (1,3,4,7,11,18,29,47...); or it can be paired with 4 and quickly become another Phi(?) sequence (1,4,5,9,14,23,37,60...); or it can be paired with 5 and quickly become yet another a Phi(?) sequence (1,5,6,11,17,28,45,73,118...), and so on, as plotted below on the graph. The sequence could also begin with 2, or 3, and 10 trillion, and the ratios between the numbers in that vector will all eventually tend towards Phi(?).

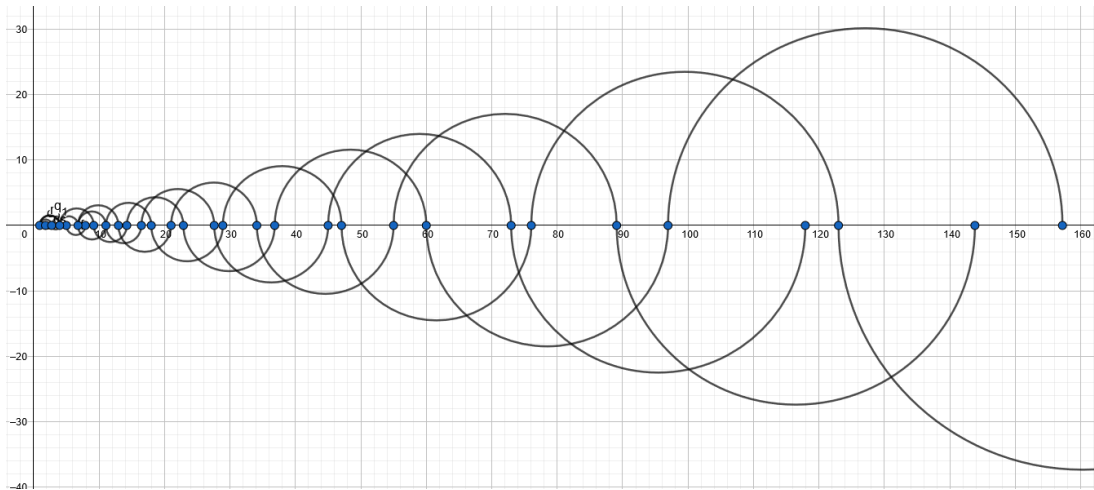

This connection between any two numbers is essentially unique to the Phi(?) ratio. Since ANY two numbers can give us a Phi(?) sequence, ALL numbers can generate a Phi(?) sequence. The only other sequence that will include all numbers is that of adding 1, whose ratio will tend to 1 (i.e. 10001/10000). We have already seen the special relationship between Phi(?) and 1:

$$1 + \frac{1}{1 + \frac{1}{1 + \frac{1}{1 + \frac{1}{1 + \dots}}}}$$

$$\phi = \sqrt{1 + \sqrt{1 + \sqrt{1 + \sqrt{1 + \sqrt{1 + \sqrt{1 + \sqrt{1 + \dots}}}}}}}$$



Each of those endless Phi(?) vectors can also be a Phi(?) spiral, in other words, the most efficient growth plane that both numbers can be on. This can be a 2-d, 3-d, or n th dimensional spiral that emanates circularly from the first point (number) in the sequence, or it can generate in any dimension linearly as below:

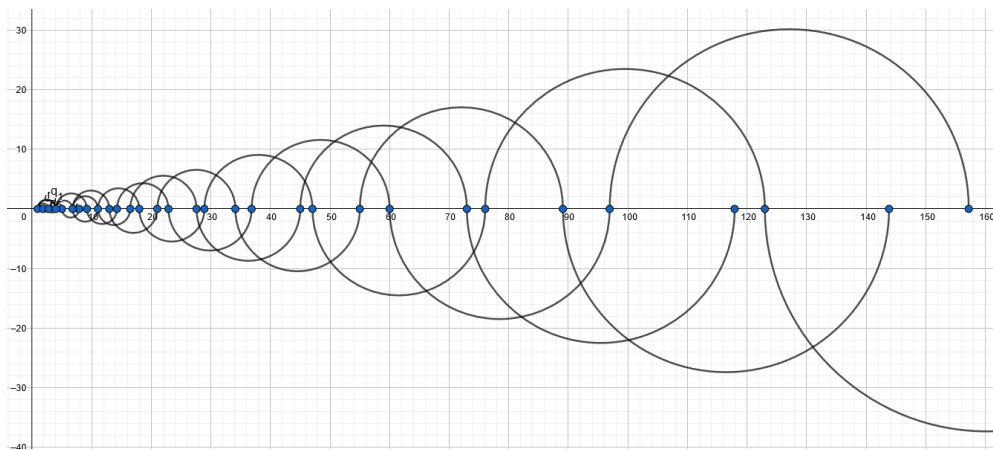

In this case, the vortex pictured is generated by starting with one(1) and continually extending the second number in the sequence by one(1) and then overlapping the new intervals, which each tend to Phi(?). We could draw an infinite number of Phi(?) vector or spirals from our chosen starting point of 1. It would not change the $\mathbf{Phi^3/2}$ angle of the spiral one bit, but it would plot (fill in) all the points along the angle, and give us a finely ribbed spiral. The semi-circles in the graph, which obviously must obey Pi, increase in size in the Phi(?) proportion as well. [The Math behind the Vortex as illustrated in the next few exerted diagrams can be found here.](#)

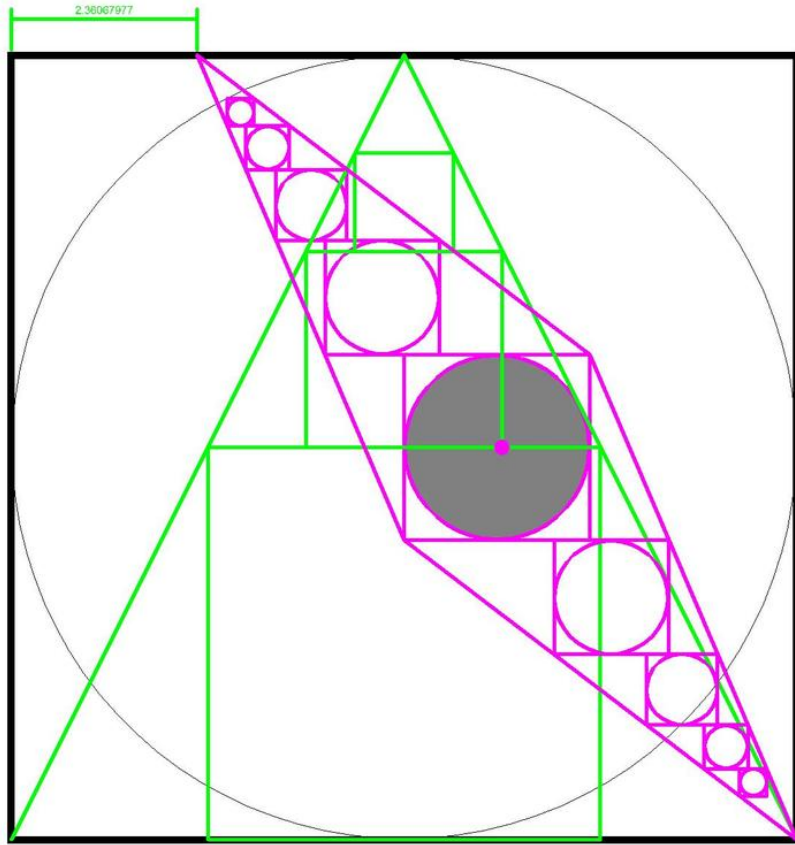

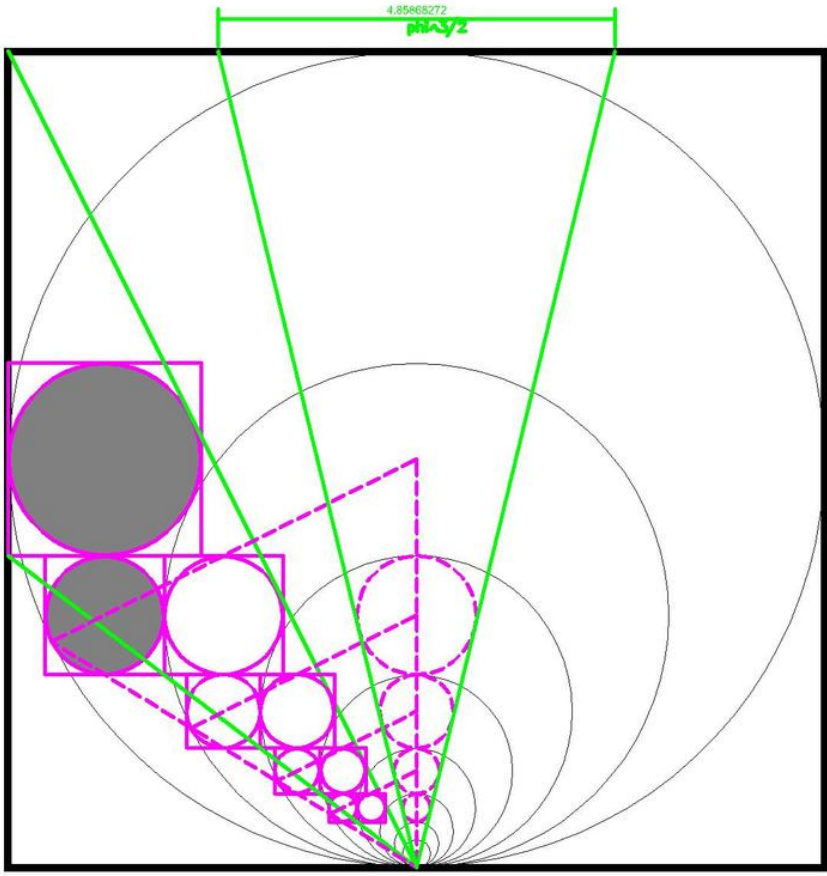

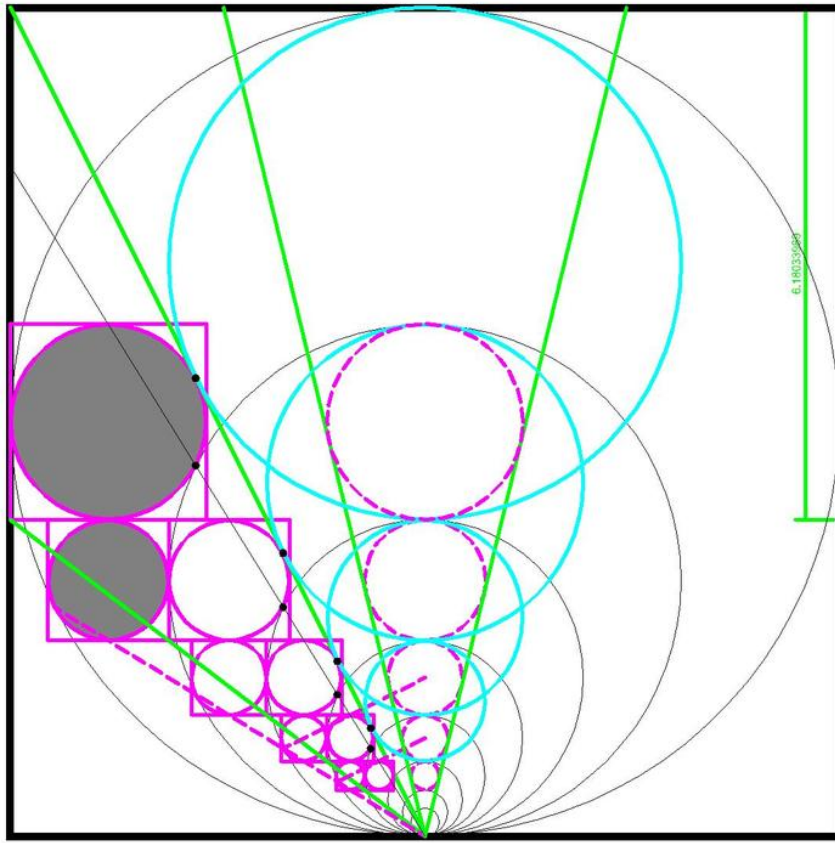

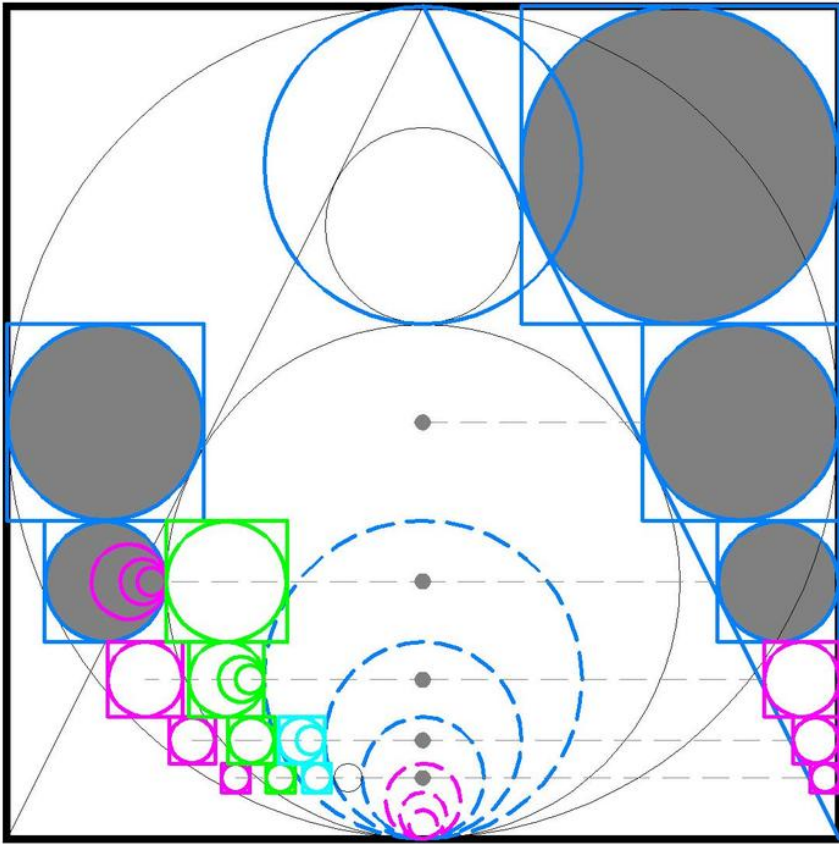

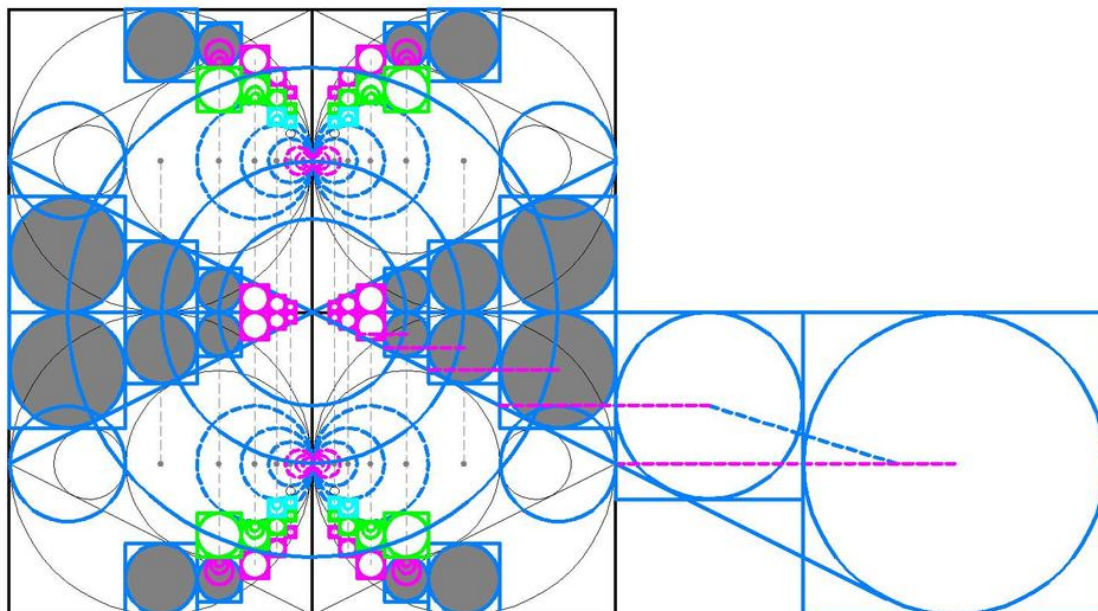

All these vortex generating elements were presented within the confines of a cube. Just like the **100 Phi³** cube that contains the exact volume of the Third Holy Temple. Consistent design. Consistent alignment.

Let us not forget that a circle inscribed in a square has a ration of **1.273** with that square as in the **401,273** elements in the Torah that connect to the *Shema* and Phi(?).

Connecting the Dots Between Dimensions

Please note that given what we just learned about any two integers, each and every integer, positive and negative has an infinite number of Phi(?) spirals emanating from it, each one a separate vortex, similar in shape, but ultimately unique as they all contain unique data points. Each one can be a point of divergence or emanation into our world in the endless plane of Inertia.

The plane of Inertia (potentiality) is the on/off switch, the triggering mechanism that causes divergence and convergence to occur in our world, whether it be magnetism, electricity, or desire.

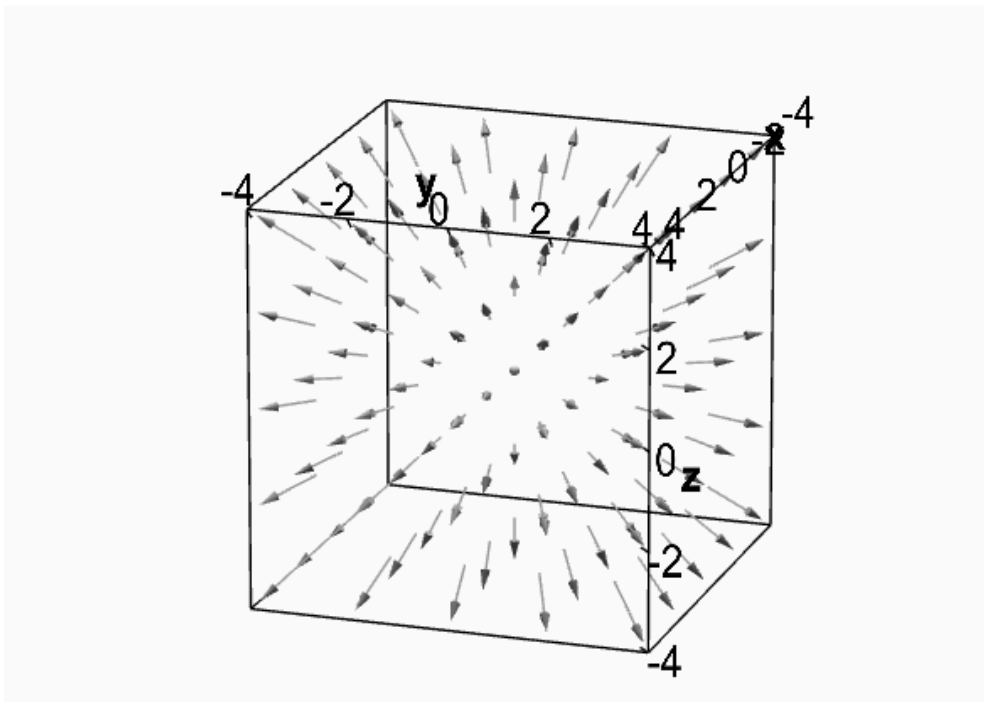

Ken Wheeler and others have isolated four (4) forms of energy movements that react to, or are in response to, the interaction with of the *Binah* Plane of Potentiality. These would be the four (4) forms of energy movement of *Zeir Anpin*. They are radial movement, circular movement, counterspatial movement and spatial movement. Radial movement is parallel polarized linear movement, but not necessarily confined to Euclidean geometry. Counterspatial is what know in vector field analysis as curl, sink, or convergent movement, and Spatial movement is analogous to divergent movement. We will not go into the math of physics behind this schematic as it is too complex for this forum.

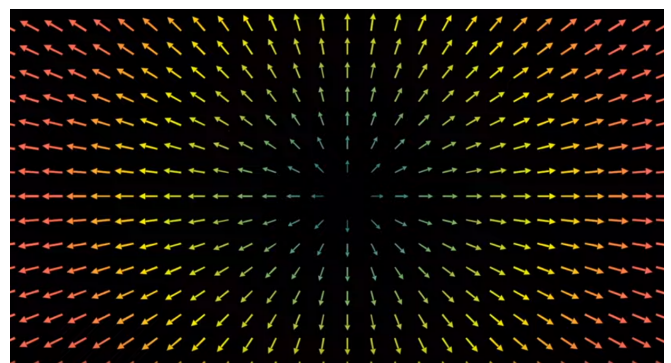
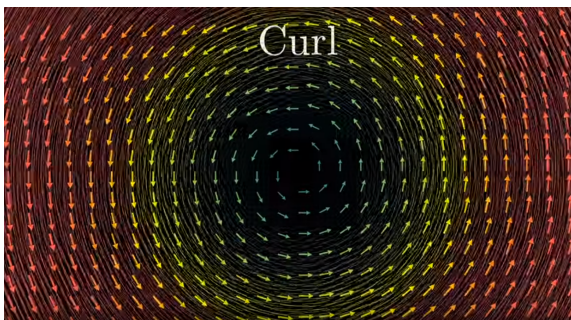

In truth, this is just a theory, but so is space time, and particle physics for that matter, and while gravity seems awfully real to us, it is just an observed reaction to something still completely unknown to us. Whether theoretical, or real, these 4 forces (movements) do correspond nicely to our 4 Essential Forces of the Universe, as transcribed to us with the 4 sets of Triplets in the Torah. The 4 forces (movements) are also depicted in the 95th unique word of the Torah, the Tetragrammaton (????):

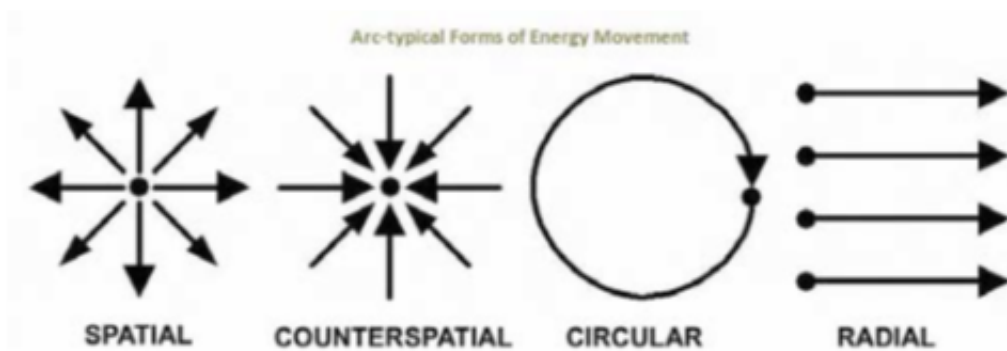

The four (4) forms of energy movement are given in no particular order, so let us rearrange them to begin with the simplest, the circular movement:

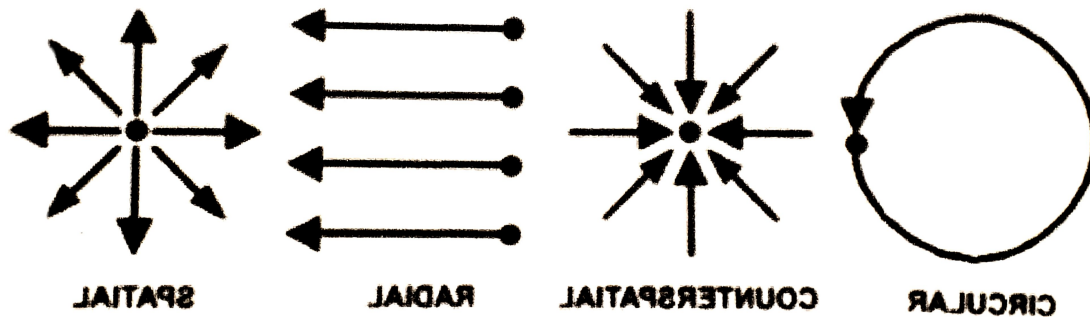

Since the radial rays can be in any parallel direction, let us switch them to vertical:

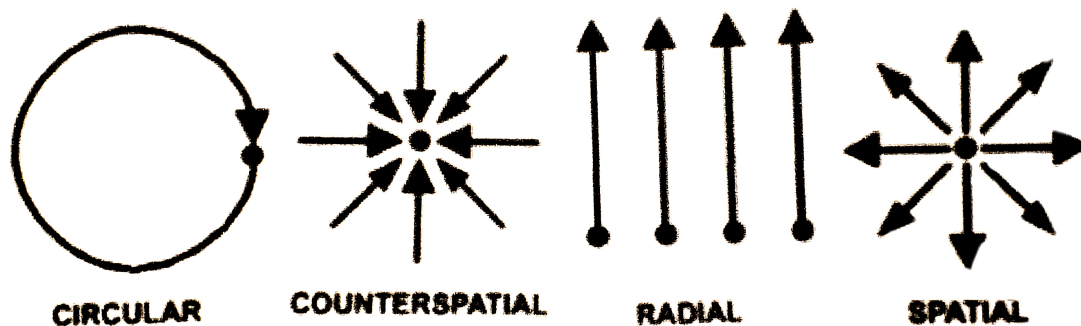

We do not need to show all the rays, one of two will do fine, and the circular motion could be as small as a point:

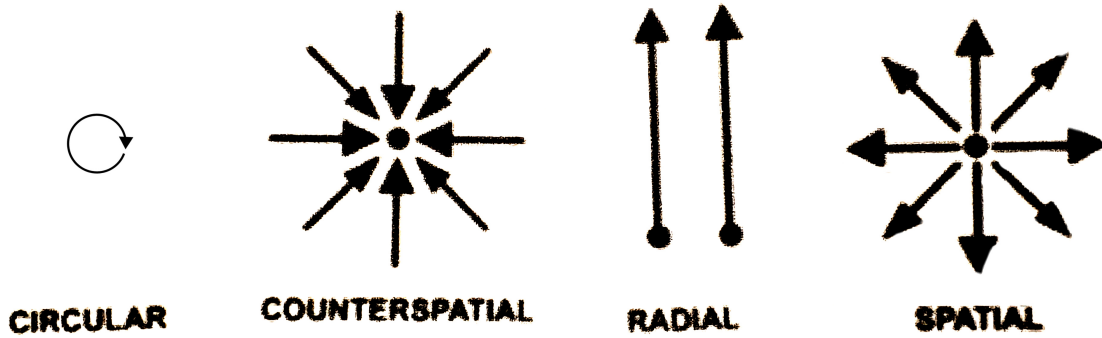

Now, let us flip their order, as if we were reading from right to left, as in Hebrew. Again, the order makes no difference as far, as we know:

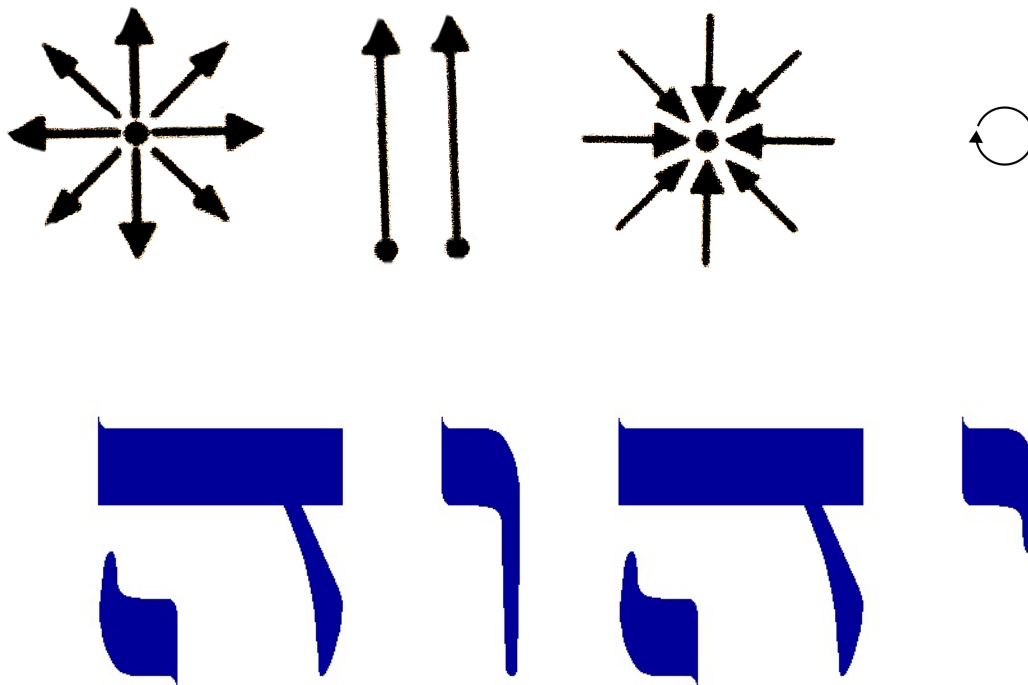

The point source, circular motion, would nicely conform to the *Yud(?)*. The two *Heis(?)* are equal looking, but we know from the Kabbalists that they are similar, but opposite in nature, just like the counter spatial or curling/convergency and the spatial or divergent movement. The spatial dimension would correspond to our realm, while the counter spatial would be at a higher dimensional level within *Zeir Anpin*. The radial, or ray, would be recognizably equivalent to the *Vav(?)*.

Depending on how much true studying of Kabbalah you may have done, you may have thought that there was more to the Tetragrammaton(????) than just 4 letters. You may have felt that they are connected to G-d, G-d's Name, an aspect of G-d, or G-d's energy in some way. You may even have known that they can be used in unifications, known how to use them, or even used them properly to make the proper unifications. Did you realize, though, how significant they truly are, or why the Torah made us focus on this Name (????) 1820 times? They are a system. They are our portal to Understanding. They are telling us how our universe works, how we can succeed in it, and how we can bridge this world to elevate to the next.

Let us examine the Tetragrammaton(????) again in yet a new light. And let us look at the field

forces behind electricity and magnetism.

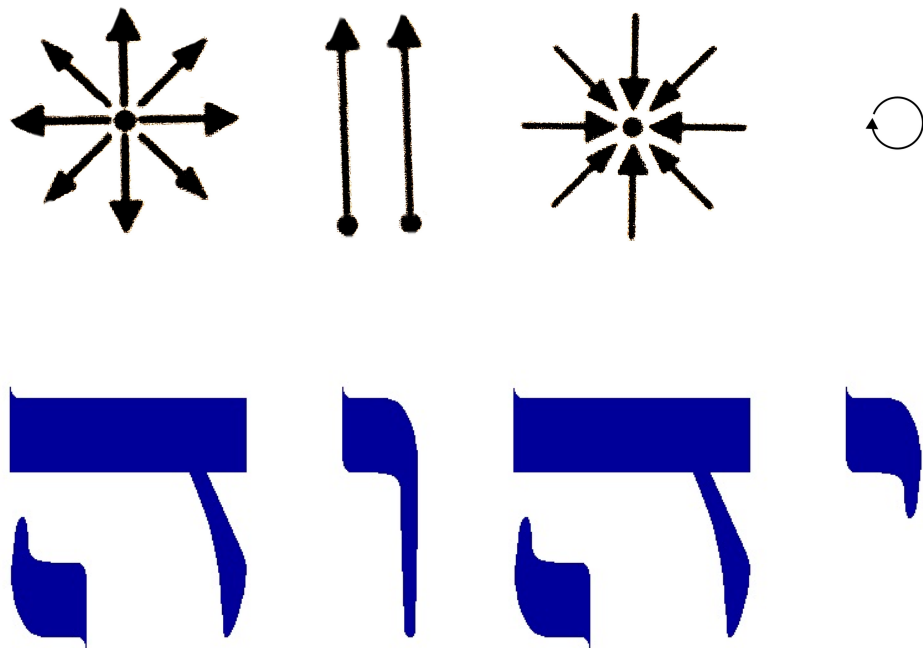
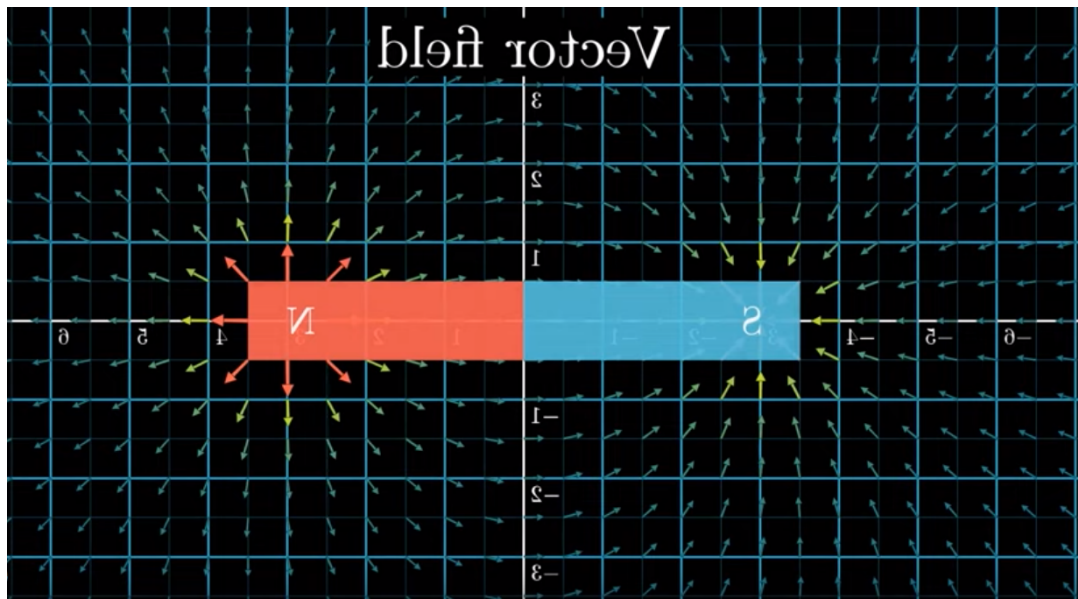

The vector field in the diagram depicts the dielectric field and only the dielectric field, and we can clearly see how the curl/sink/convergent vectors are on the Southern region, corresponding to the first *Hei(?)* of the Tetragrammaton(????), and the divergent vectors emanate from the

Northern region, which corresponds to the final *Hei(?)*. Always midway between them is polarized a vertical line of parallel perpendicular vectors, which we have learned is the plane of Inertia(Potential). We can call that line or plane the *Vav(?)*. The *Yud(?)* is the extraneous force on yet another dimension that commands the *Vav(?)* or the plane of Inertia, and flips it on and off, activating the two equal and opposite forces.

We have discussed, and most students of Kabbalah know about, the 3-column system of the 10 *sefirot*(dimensions): right (mercy), left (judgment) and center (restraint/balance). There is one organization that has sold the central column as restriction and conveniently mis-quoted Rav Ashlag about the meaning of restriction. The theory goes if you restrict or resist the flowing light the way the filament in a light bulb restricts the electricity in a circuit you will create light. Think about it. That is saying that if you are a poor conductor of light (electricity) you will be converted into the creator of light, and if you are a good channel of current nothing will come of it. It makes no common sense and shows no understanding of the process. The central column is potentiality, not restriction. It is not neutral. It is in a pure potential state. It is the plane of Inertia, the *Vav(?)*. It is what is truly meant in Kabbalistic terms, "letting go." You let go of all your worldly desires and align yourself with pure potential, with the plane of *Binah*. The *Yud(?)* of *Chochma* will then engage the Plane of Potentiality, *Binah*, *Vav(?)*, which in turn will direct the circuitry of Light to flow freely through you as a perfect reflection of above.

When we engage, or falsely manipulate, our desires we corrupt the circuits, inadvertently blocking the potential benefits of the Light(life) force, and we find ourselves trapped in the circuitry of the physical. It is an on/off switch. When we are in tuned to our desires it is off. Yes, we are speaking about the desire for the self alone, but most of our desires to share are with agendas, and are only to ultimately receive something in return, so in the end they are just desires for the self alone.

This circuitry happens on multiple levels, each dependent on the one above. The lowest level is the physical realm where the forces can be manipulated and corrupted to enrich some (convergence) and rob or draw from others (divergence). This is the realm where the outcome of the circuitry produces electricity and magnetism on multiple scales. This the realm where the circuitry produces attraction and repulsion. It is all about desire, the desire to have something we want, or to get away from something that we do not, or to get rid of something that we have and do not want, like a disease. It is a zero-sum game down here. Do not kid yourself, it is almost never that we want something for the sake of the universe alone.

Our world only reacts to the world of *Zeir Anpin*, the next level up, the level of the (????). That is where the true Light of the upper worlds sets the schematics for what happens in our world. When the *Binah* Plane of Inertia or Potentiality opens (aligns) on that level, and divergent and convergent circuits are set in motion, the effect down here is felt as a polarization, an attraction or repulsion to the aspect of the Light. You can call it good vs evil, hatred vs love, greed vs generosity. Down here, it is all reactions, all reactivity.

The only proactivity is aligning yourself with the plane of Inertia, Potentiality. When you proactively go after something, you are just succumbing to an attracting force and telling yourself that you are in control. That is the illusion of this world. That is not to say that being proactive is not the way to enrich yourself in this world because it certainly does help. Reading the forces of attraction and repulsion and proactively using them to wrap yourself in physicality is indeed how most successful people operate. There is, of course, an equal and opposite reaction to that in *Zeir Anpin* and then *Binah*.

The level of *Zeir Anpin* answers to the level of *Binah*, and the movements within the Plane or Sea of *Binah* guide *Zeir Anpin*. There is returning light from our world indirectly communicated to *Zeir Anpin* through patterned motions, and they are then transferred to *Binah* through other coded motions or patterns in the ether. It is somewhat akin to the various passages of assorted

RNA messaging and transference from DNA to protein manufacture and cellular function. We are not speaking about a gigantic (????) is space or hyperspace; we are speaking about a system. All those infinite Phi(?) spirals intersect with one another and create infinitely more spirals and all sorts of patterns. There are infinite ways to store and transmit information. Infinite ways that one's life can follow the efficient natural path toward righteousness and enlightenment and infinite ways to stay off that path. Sometimes we connect the dots and go from 1 to 2 to 3 to 5 to 8 to 13 to 21; other times it is only after 30 that we connect 1 to 30 to 31 to 61 to 92; and there are other times that 2,4,8,16,32,64 seems like the fastest path to success and fulfilment for us. The beauty is that any two numbers (or events or moments in our lives) can set us on the right path; the calamity is that there are so many ways to disconnect or avoid connecting entirely.

Going back to our simulation scenario, whether divine, mechanical, or advanced civilization, which would all be ultimately divine, there are two players. One, the Creator, has told us His Name is G-d (????), and the other, His adversary, the one He warned us about in the very beginning of His guidebook for us, the Torah. It is the same one who we were shown works with deception, illusion and the power of attraction from the moment we were introduced to him. The Creator began the **10** Commandments in the **70th** chapter of the Torah in the **54th** paragraph of the Book of Names (*Shmot*) with the words, "I am God(???? ????)." For those that understand, in those two words He also gave us a time frame, but be that as it may, He gave us a way to Understanding, a shortcut to enlightenment. It is all in the Name (????). It is all about helping us connect to the Plane of Potentiality, the plane of no desire.

The **4** Essential Elements, or **112** Triplets, can help us do that. He gave us those too. Those sets of Triplets can help us as individuals. Then when we build the Future Holy Temple to those same coordinates, they will help everyone. Of note is that the **112** Triplets must obviously be used without desires, not as some may have sold you on, that you can meditate on prosperity, healing, luck, soul mates, love, certainty, business acumen, etc. Using the **72** Triplets (Names) that way creates the wrong type of pattern. Think about it; you cannot be letting go and yet begging for something for nothing. The only exception is the **14** Triplets of the **42**-Letter Name; they will not get you something selfish, but you will not be charged with setting a negative pattern either. Rabbi Chaim Vittal of blessed memory warned in the strictest way against using the **72** Triplets individually or for anything on the physical plane.

How do we get to the Plane of Inertia? How do we achieve that state?

Earlier in this series we explained that to attain enlightenment, we need to align our consciousness with the dimension of *Binah*; that is what aligning ourselves with the Plane of Inertia (Potential) is. The Plane of Potential is also the limitless Plane of Possibilities because if everything is in potential, everything is possible.

Can we do it? Can we actually reach that state?



Yes, the true ascendant masters have done it. The tzaddikim have done it. The Prophets too. Tesla was a master. As we said in our discussion of enlightenment, some of us can do it in our sleep or indeed have to do it there because it is too hard to control our minds and desires otherwise. For example, the Sleeping Prophet.

Besides using the **4** Essential Elements of the **112** Triplets, are there any other means to focus ourselves on that point of pure potential?

Yes, many who have achieved it did not use or know of these Elements at all, at least not that we know of. Rav Brandwein of blessed memory, and others would use the **150** Psalms. He encouraged us, his students, and everyone who asked. Now you understand why there were **150** Psalms, just like the **150** Lights the Arizal instructed us to bring down from the 3 Upper dimensions through *Binah* and into *Zeir Anpin* during the Shofar blowings.

The Creator gave us a hint about the Psalms and there connection to the Plan of Inertia found at the exact midpoint between the forces. King David was their author and at the midpoint in his **70**-year life was the exact midpoint in the calendar from Adam to *Moshiach*. That year can be found concealed in the paragraph above about the **10** Commandments in the **70th** chapter of the Torah. Try to figure it out for yourself because studying deep into the secrets of the Torah helps us reach enlightenment because it only through the Plane of Potential (*Binah*) that we can get that Understanding, which is why *Binah* is Understanding. If you need help, ask yourself when did Israel cease to have a government? After how many years of statehood?

Can we train ourselves? Is there any way to know if we have achieved that state?

Yes, and yes. We have only given some of the ways to achieve it. Remember the metal filings attracted to the dielectric field. Your dielectric field can show you what state you are in. I am not saying to use metal filings, but our dielectric field is our aura. Many of Tesla's numerous inventions were based on the dielectric.



Many of the plans for Tesla's numerous inventions based on the dielectric were carted off and secretly built or suppressed, among those was a biofeedback system for developing an alignment with the Plane of Potential. It is still being used. By the way, this Plane, this Field, is what is known in Star Wars as "The Force." Static electricity and lightning follow the dielectric field; that is what the Tesla coil is all about. What we are saying is that there are ways, natural and otherwise, to read your alignment with the field and then through biofeedback learn how to stay there.

One caveat is that the path of enlightenment is not a path to riches, not in this world anyway. It is anathema to that. You cannot pursue pure potential without forsaking desire, and you cannot achieve riches in this world without desire. Most of those that achieved this state were not wealthy, not even Tesla, the man responsible for most of our economy today. There are notable

exceptions like Joseph, who naturally attracted wealth and used it righteously. Even he, the Torah shows us nearly succumbed to a state of desire and suffered for it. Jacob, who represents the central column, on the other hand lived a life with much suffering. He is the archetype of the central column.

The Four Movements Inscribed in Stone

In this series, we have often drawn parallels with the dimensions of the Pyramid in Egypt. We would like to draw one more, to the 4-symbol engraving found hidden in a niche beneath the massive entrance lintels, which were themselves hidden for thousands of years beneath layers of stone and a sheath of polished casing stones.

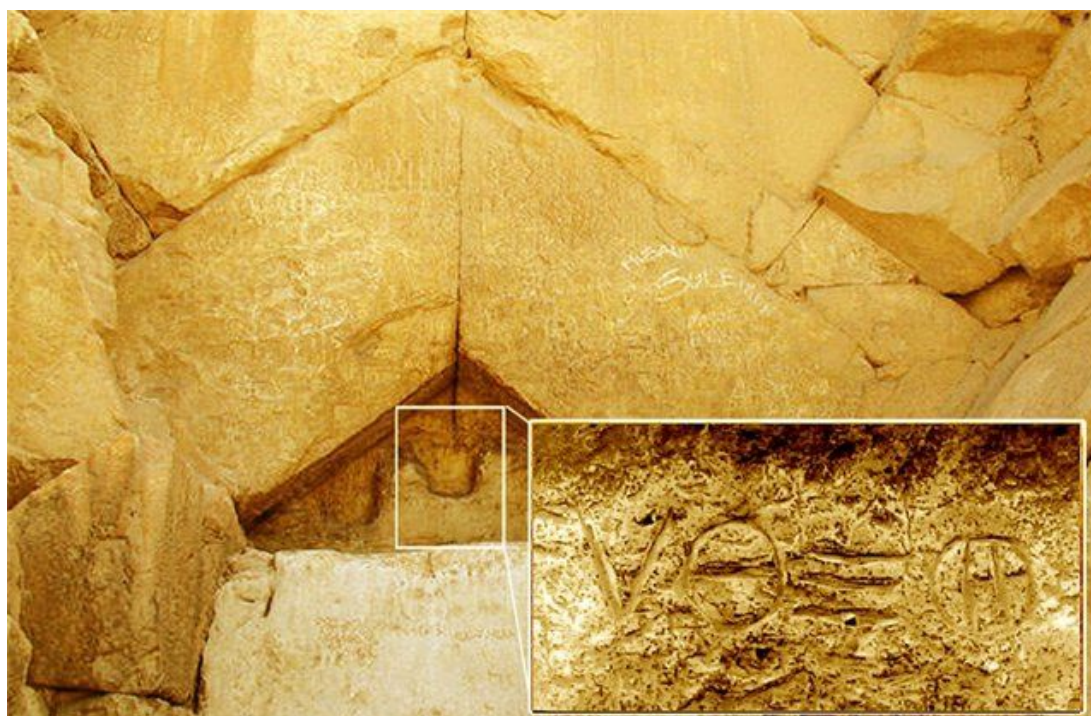

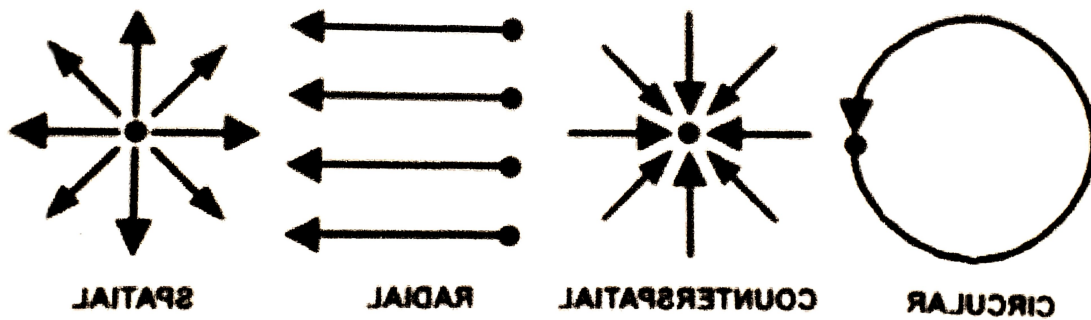

The resemblance to the four essential motions of our universe are uncanny, including the second and fourth symbols being equal and opposite like the two *Heis*(??) of the Tetragrammton (????) and the two motions of divergence and convergence. The third symbol could not be any more perfect, and whether the first symbol is a point spreading outward, a directional symbol, a *Yud* (?) as many scholars insist, it is different from the others. It is easy to see it as a Tetragrammton (????), but honestly to do that the symbol would have to have been written upside down.

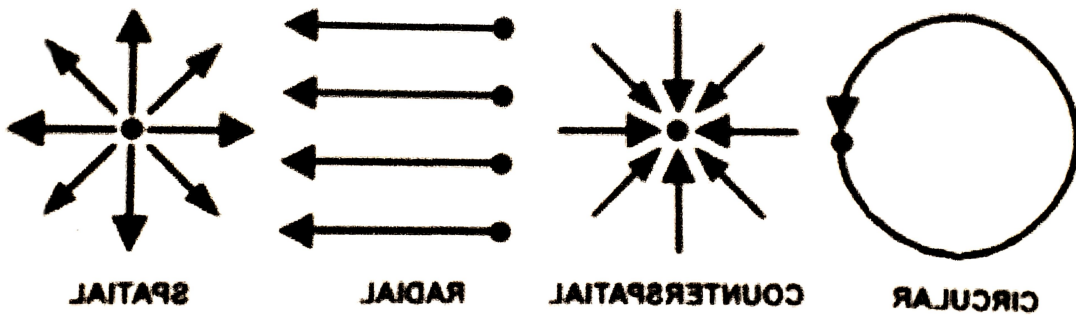

Thinking about the series of symbols we sent out on the Voyager spacecraft, even though it was a meaningless gesture, we would have shown off our intelligence much more if we included these symbols along with the Tetragrammaton (????). Then, at least, whoever found it would know the depth of our understanding and the direction we were going in.

Due to the length of this section, we will continue with our discussion about water in the next section, hopefully to follow before *Zot Chanukah*. During these eight (8) days the Light of *Binah* and *Moshiach* is available to us. It is the ideal time to focus on the state of potentiality. With each candle you light you must see yourself drawing down the river (**NaChal**) of potentiality from the upper 3 dimensions through *Binah* through *Zeir Anpin* and into your life and world. Stay there as long you as you can. **NaChal** is **Notzer Chesed La'alufim** (????? ??????????) from the 13 attributes. It is *L'hadleek Ner Chanukah*. [This is directly from the Arizal.](#)

... להדליק נר זנוכה

יוד הא ואה אהייהו הא

[נוצר זוסד לאלפים]

The Light or force from *Binah* expressed in the regressive *Ehyeh* is entering through the *Vav* (???), the Plane of Potential and Possibilities.

May your year be filled with endless possibilities.



Chanukah Sameach

Ezra

For anyone that has not been following this series from its inception, you can find the [entire work here](#).